

Transmission Oil Cooling and Warming Products

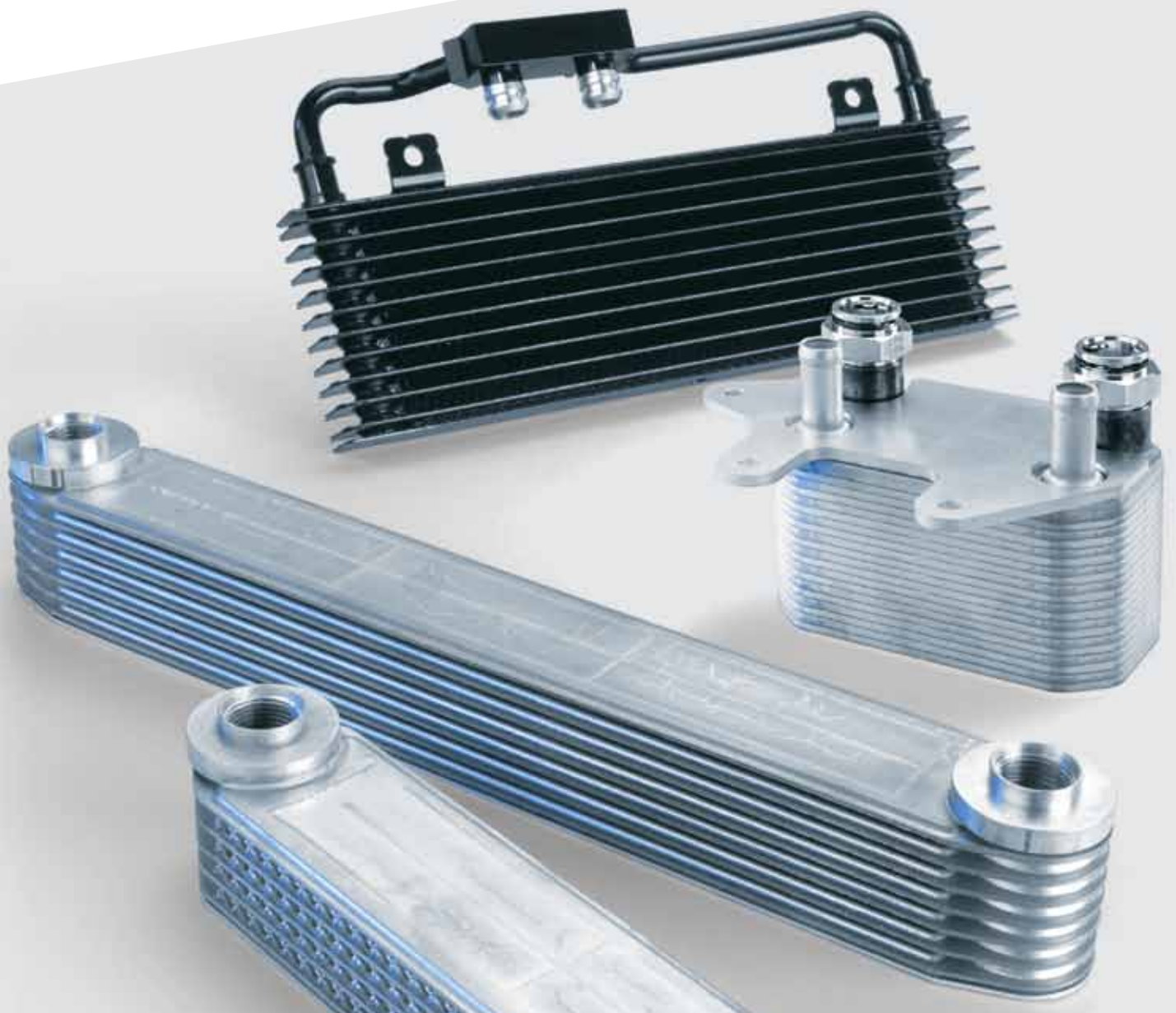

LONG[®]
Thermal Products



Thermal-Management Products

Dana, the leading transmission oil cooler manufacturer in the world, offers a full range of innovative heat-exchange solutions – both air- and coolant-cooled – to meet your unique needs.

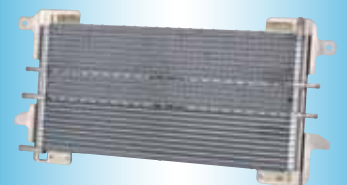

Liquid-to-Liquid Heat Exchangers



Aluminum Self-Contained Cooling and Warming Products

Length (mm)	94	110	140	148	120	140	172	210	327
Width (mm)	62	70	70	74	80	80	69	94	100



Stainless Steel Self-Contained Cooling Products

Length (mm)	203
Width (mm)	116



Aluminum and Brass Radiator In-Tank Products

Length (mm)	210	254	292	300	305				
Width (mm)	28	28	36	44.5	44	45	28	36	44.5



Aluminum and Brass Radiator In-Tank Products

Length (mm)	Designed to customer specifications								
Diameter (mm)	19	22	25.4	28	32	38	44.5		



Stainless Steel Radiator In-Tank Products

Length (mm)	216	292	457
Width (mm)	44	63.5	76.2

Liquid-to-Air Heat Exchangers

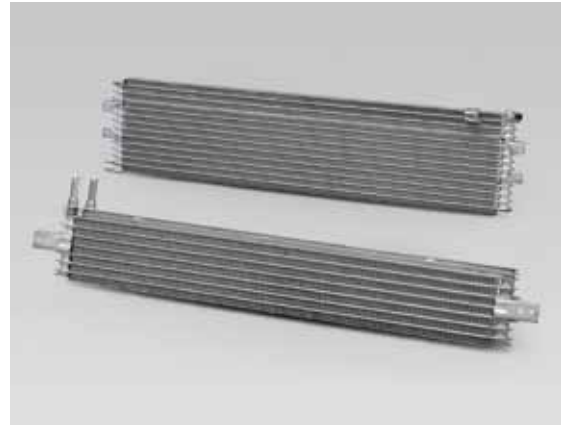
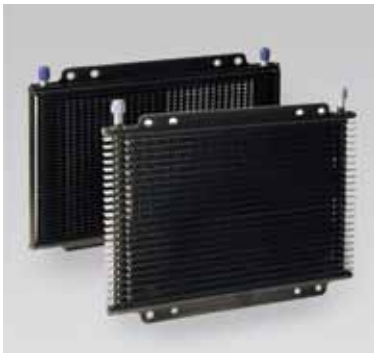

Plate and Fin Design

Core Depth (mm)	19	20	32	32	50
Core Length (mm)	280, 580, 670	212	158, 253, 340, 580	400 to 850 (max.)	277, 355
Core Height (mm)	Designed to customer specifications				
Fin Density (fins per inch)	Designed to customer specifications				



Stacked Plate Design

Core Depth (mm)	19	19	38
Core Length (mm)	102	280	280
Core Height (mm)	Designed to customer specifications		



Combination Coolers

Designed to customer specifications

Active and Passive Warm-Up Products

Thermal management is a critical area of engine design. A certain percentage of fuel has to be consumed in order to overcome friction in powertrain components such as the transmission, engine, and axle. To enhance vehicle efficiency, a reduction of this friction is necessary. Dana engineers found that maintaining hot oils in the powertrain increased both efficiency and overall fuel economy.

Two techniques that help maintain optimum hot oil temperatures, especially in cold climates where it takes longer for engines to meet optimum operating temperatures, are:

- Capturing the thermal energy generated inside each component
- Bringing in external, otherwise wasted, thermal energy from the vehicle cooling and exhaust systems to warm engine oils

Thermal Bypass Valve (TBV)

This device prevents cold or partially warmed oils from leaving powertrain components such as the transmission. Internal circulation of vehicle oils keeps thermal energy from dissipating and consequently improves efficiency.

Active Warm-Up (AWU)

In most vehicle applications in the northern hemisphere, heat generated internally is not sufficient to bring oils to optimum temperature quickly enough to reduce friction or parasitic losses. AWU uses otherwise wasted thermal energies, such as heat lost through cooling systems or engine exhaust, to warm these oils – even above what can be achieved through TBVs alone.

The combination of these two technologies creates an integrated system that reduces complexity and increases the system's response time, bringing vehicle oils to optimum operating temperature quickly and maintaining it, resulting in a significant reduction of fuel consumption and emissions.

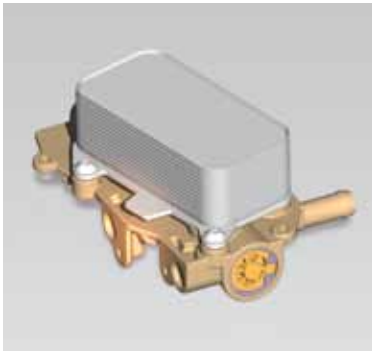

Stand Alone							
Length (mm)	61	25	41	52	52	60	48
Width (mm)	20	23	23	23	23	33	45
Height (mm)	61	69	71	70	74	77	71

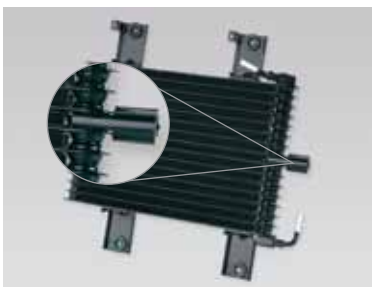

Integrated with Heat Exchanger
Designed to customer specifications

Thermal Bypass Valve Cartridges
Designed to customer specifications

Dana Power Technologies Group
Global Research and Development Locations

Lisle, Illinois, USA
Gravatá, Brazil

Paris, Tennessee, USA
Wuxi, China

Oakville, Ontario, Canada
Neu-Ulm, Germany

Pune, India



LONG[®]
Thermal Products

For more information, please call 1-888-670-DANA (3262) or visit www.dana.com

Application Policy

Capacity ratings, features, and specifications vary depending upon the model and type of service. Application approvals must be obtained from Dana; contact your representative for application approval. We reserve the right to change or modify our product specifications, configurations, or dimensions at any time without notice.